



KIKAWA

木川水平多段式泵浦

Horizontal Multistage Pump

KH02/04/08/12 系列



ISO9001 認證合格



木川工業股份有限公司
KIKAWA PUMP CO., LTD





● 特點

- § 多段離心式同軸設計，用途廣泛，滿足各種不同揚程與水量需求。
- § 不銹鋼沖壓導水器與葉輪，運轉效率高。
- § 最大工作環境溫度： $+40^{\circ}\text{C}$
- § 工作流體溫度範圍：
 $+0^{\circ}\text{C} \sim +90^{\circ}\text{C}$ (Viton/SiC 耐溫型軸封)
- § 最高入口壓力限制： 6 kg/cm^2
- § 最高工作壓力限制： 10 kg/cm^2
- § 馬達防護等級： IP 54
- § 馬達絕緣等級： F

● 用途

- § 公寓住宅給水、供水系統加壓
- § 工業用水、切削冷卻水循環
- § 清洗設備供水、冷凍空調用水循環
- § 園藝、農業灌溉用途

● 型式說明

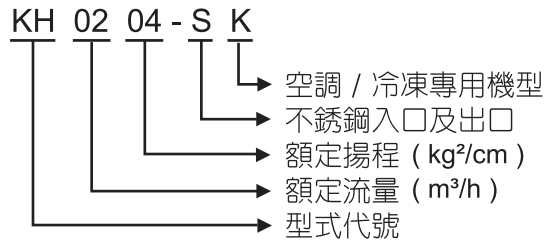

● 性能範圍

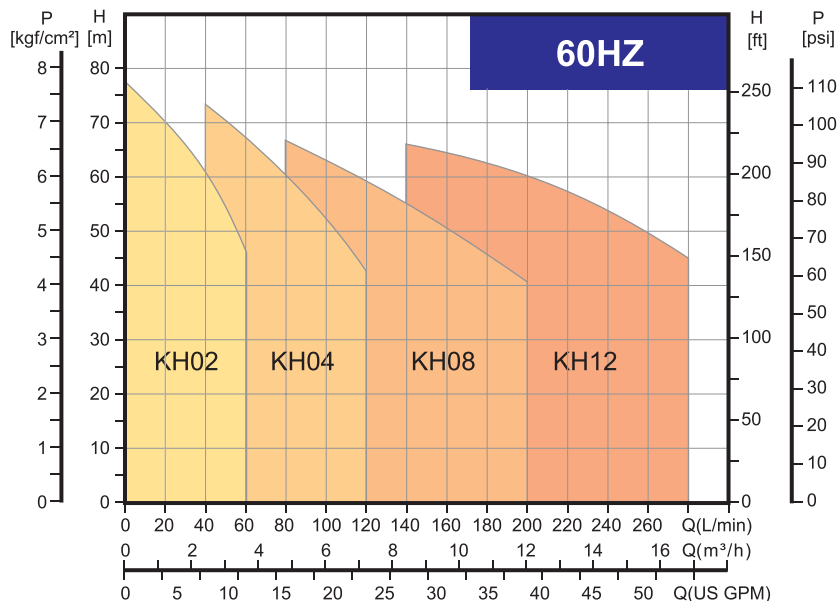
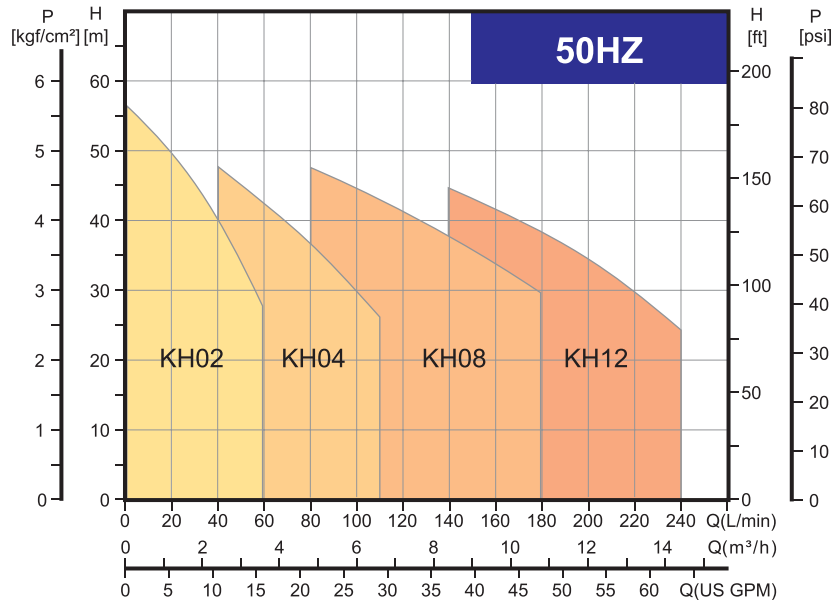



● 性能曲線

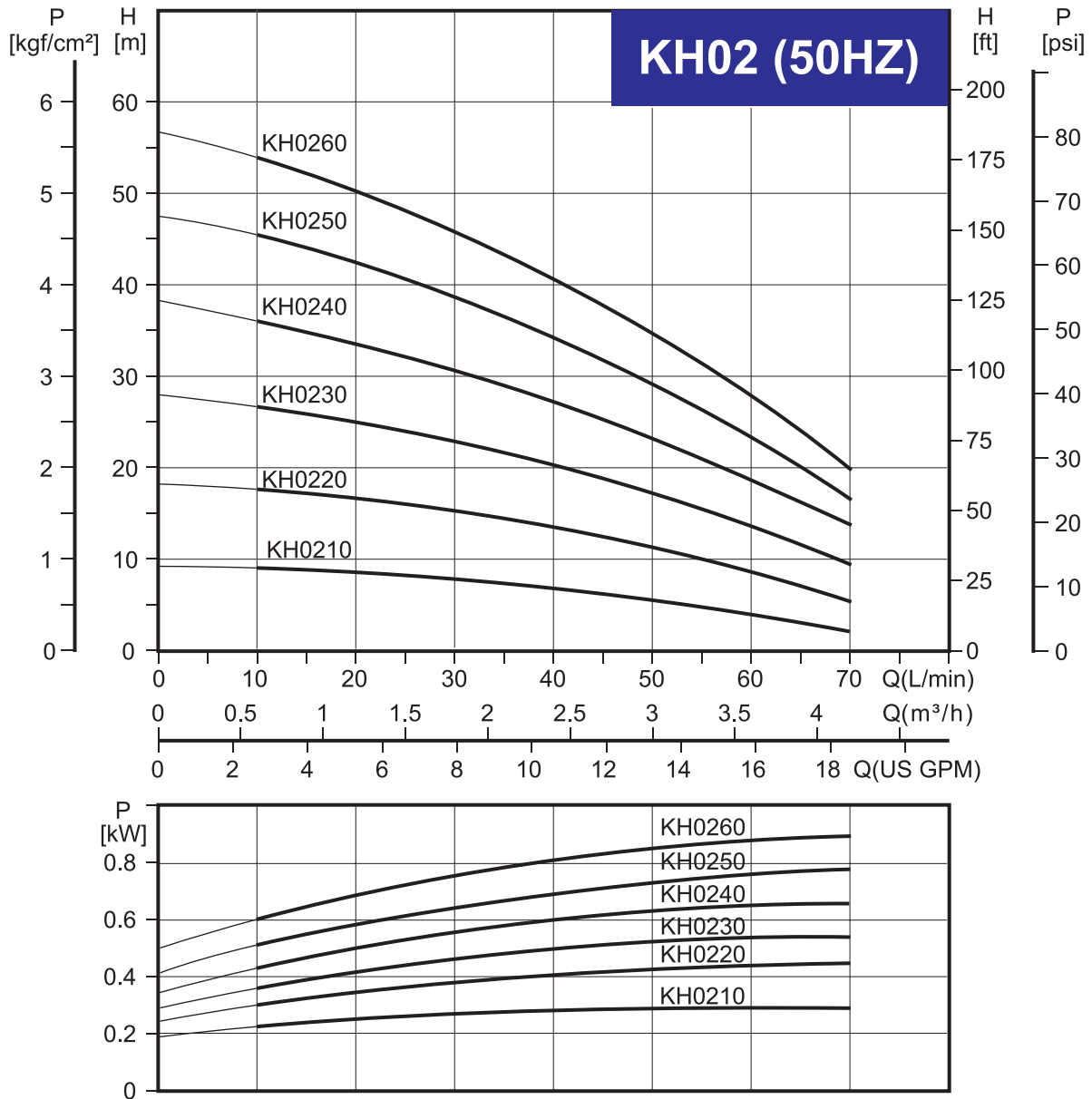

● 規格及電氣資料 (50Hz, 2850 rpm)

型式	額定輸入 (kW)	額定流量 (l/min)	額定揚程 (m)	最高揚程 (m)	相數 (Ø)	電壓 (V)	輸入電流 (A)	訂購編號(*)
KH0210	0.30	40	7	9	1	220~240	1.3	KH0210512
					3	200~255 / 380~440	1.4 / 0.8	KH0210530
KH0220	0.45	40	14	18	1	220~240	1.6	KH0220512
					3	200~255 / 380~440	1.6 / 0.9	KH0220530
KH0230	0.55	40	20	28	1	220~240	2.2	KH0230512
					3	200~255 / 380~440	1.8 / 1.0	KH0230530
KH0240	0.65	40	27	38	1	220~240	2.9	KH0240512
					3	200~255 / 380~440	2.4 / 1.4	KH0240530
KH0250	0.75	40	34	47	1	220~240	3.3	KH0250512
					3	200~255 / 380~440	2.8 / 1.7	KH0250530
KH0260	0.90	40	40	56	1	220~240	3.8	KH0260512
					3	200~255 / 380~440	3.1 / 1.9	KH0260530

(*) 特殊規格附加碼置於訂購編號後面



● 性能曲線

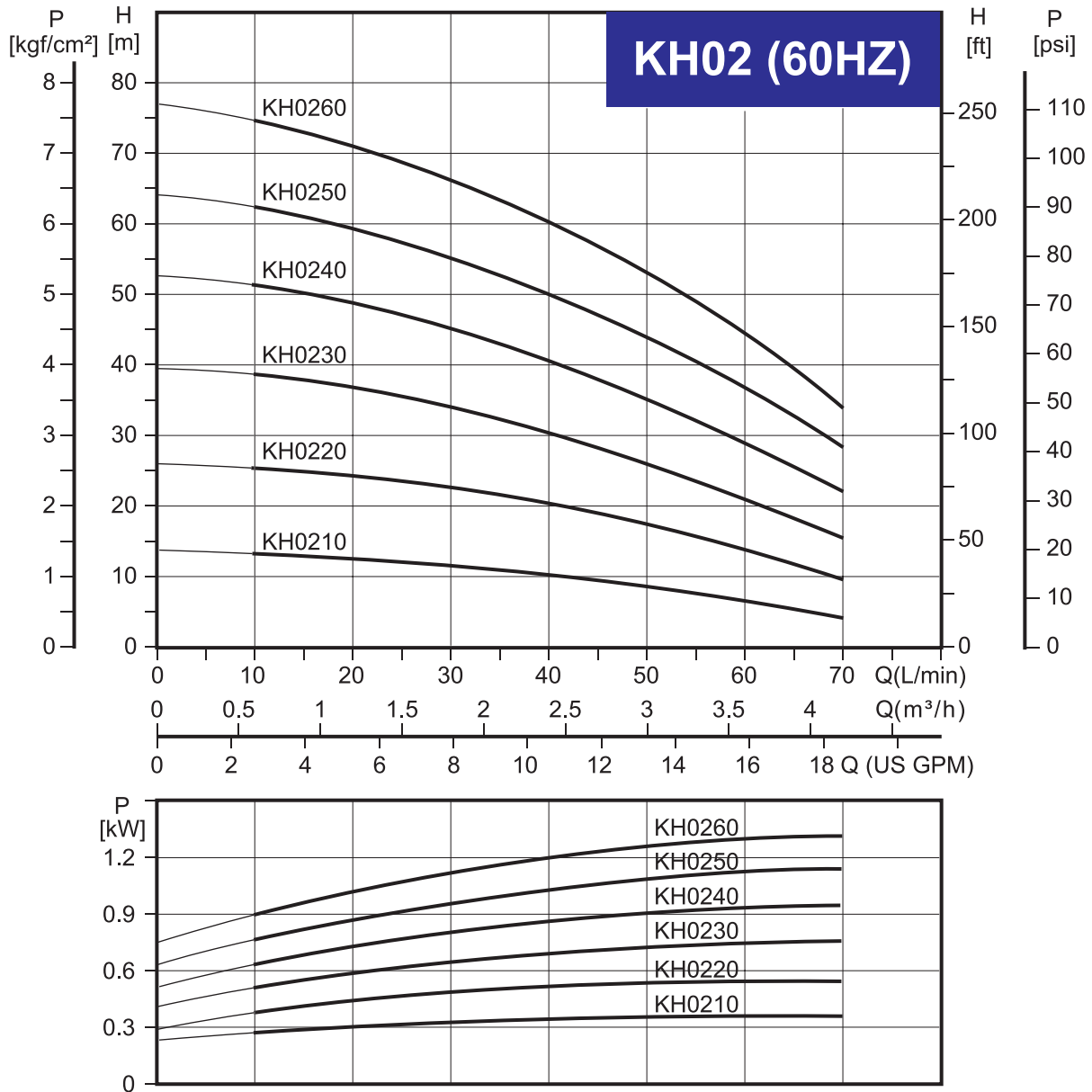

● 規格及電氣資料 (60Hz, 3450 rpm)

型式	額定輸入 (kW)	額定流量 (l/min)	額定揚程 (m)	最高揚程 (m)	相數 (∅)	電壓 (V)	輸入電流 (A)	訂購編號(*)
KH0210	0.35	40	10	13	1	110~120 / 220~240	3.2 / 1.6	KH0210610
					3	220~240 / 380~415	1.4 / 0.8	KH0210630
KH0220	0.55	40	20	25	1	110~120 / 220~240	5.2 / 2.6	KH0220610
					3	220~240 / 380~415	1.8 / 1.0	KH0220630
KH0230	0.75	40	30	38	1	110~120 / 220~240	7.0 / 3.5	KH0230610
					3	220~240 / 380~415	2.4 / 1.4	KH0230630
KH0240	0.95	40	40	52	1	110~120 / 220~240	9.2 / 4.6	KH0240610
					3	220~240 / 380~415	2.8 / 1.6	KH0240630
KH0250	1.15	40	50	64	1	220~240	5.6	KH0250612
					3	220~240 / 380~415	3.3 / 1.9	KH0250630
KH0260	1.35	40	60	75	1	220~240	6.7	KH0260612
					3	220~240 / 380~415	4.0 / 2.3	KH0260630

(*) 特殊規格附加碼置於訂購編號後面



● 性能曲線

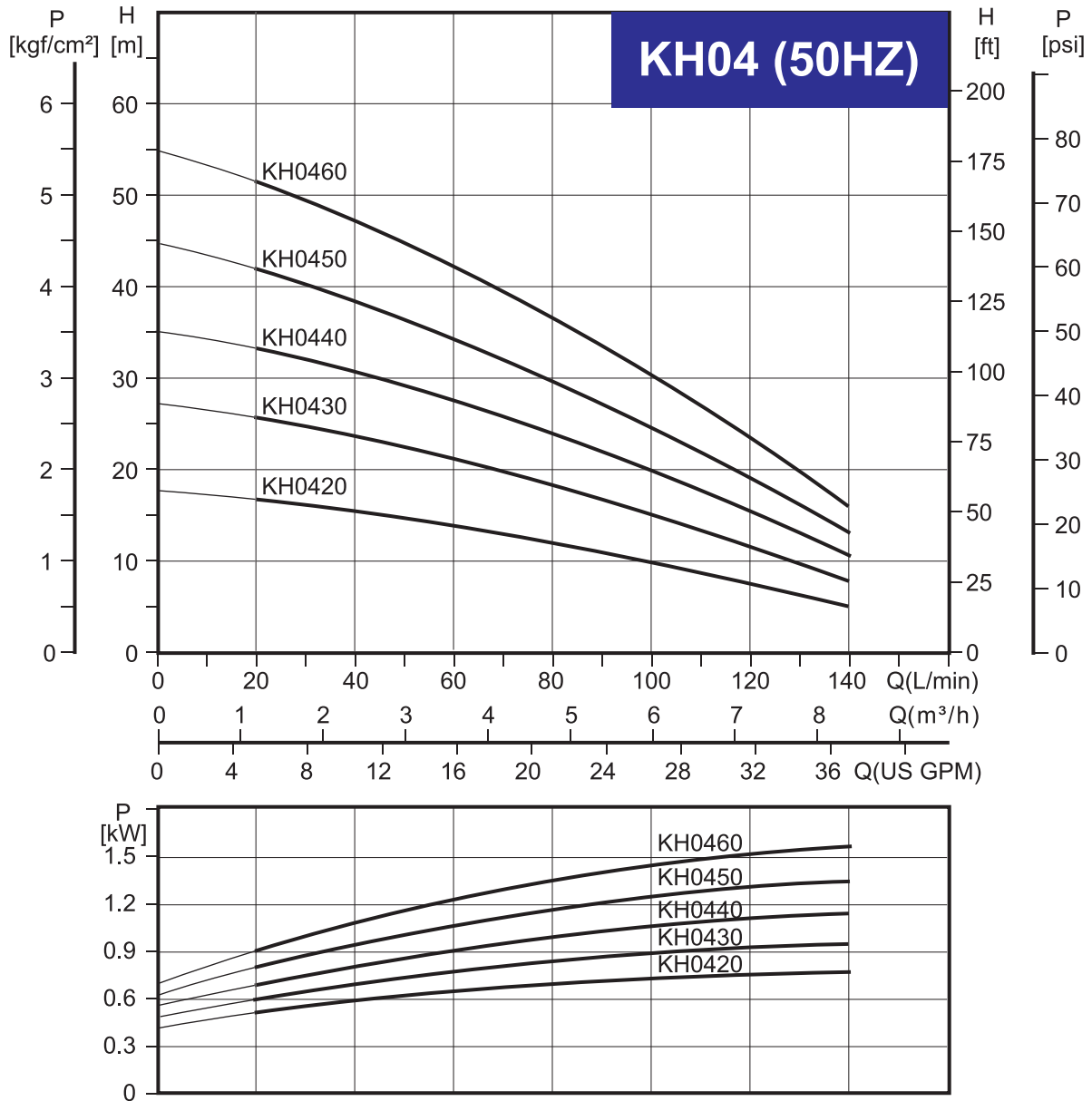

● 規格及電氣資料 (50Hz, 2850 rpm)

型式	額定輸入 (kW)	額定流量 (l/min)	額定揚程 (m)	最高揚程 (m)	相數 (∅)	電壓 (V)	輸入電流 (A)	訂購編號(*)
KH0420	0.75	80	12	18	1	220~240	3.3	KH0420512
					3	200~255 / 380~440	2.3 / 1.3	KH0420530
KH0430	0.95	80	18	27	1	220~240	3.8	KH0430512
					3	200~255 / 380~440	3.1 / 1.8	KH0430530
KH0440	1.15	80	24	35	1	220~240	5.0	KH0440512
					3	200~255 / 380~440	3.5 / 2.0	KH0440530
KH0450	1.35	80	30	44	1	220~240	6.2	KH0450512
					3	200~255 / 380~440	3.8 / 2.2	KH0450530
KH0460	1.55	80	36	53	1	220~240	7.8	KH0460512
					3	200~255 / 380~440	5.0 / 3.0	KH0460530

(*) 特殊規格附加碼置於訂購編號後面



● 性能曲線

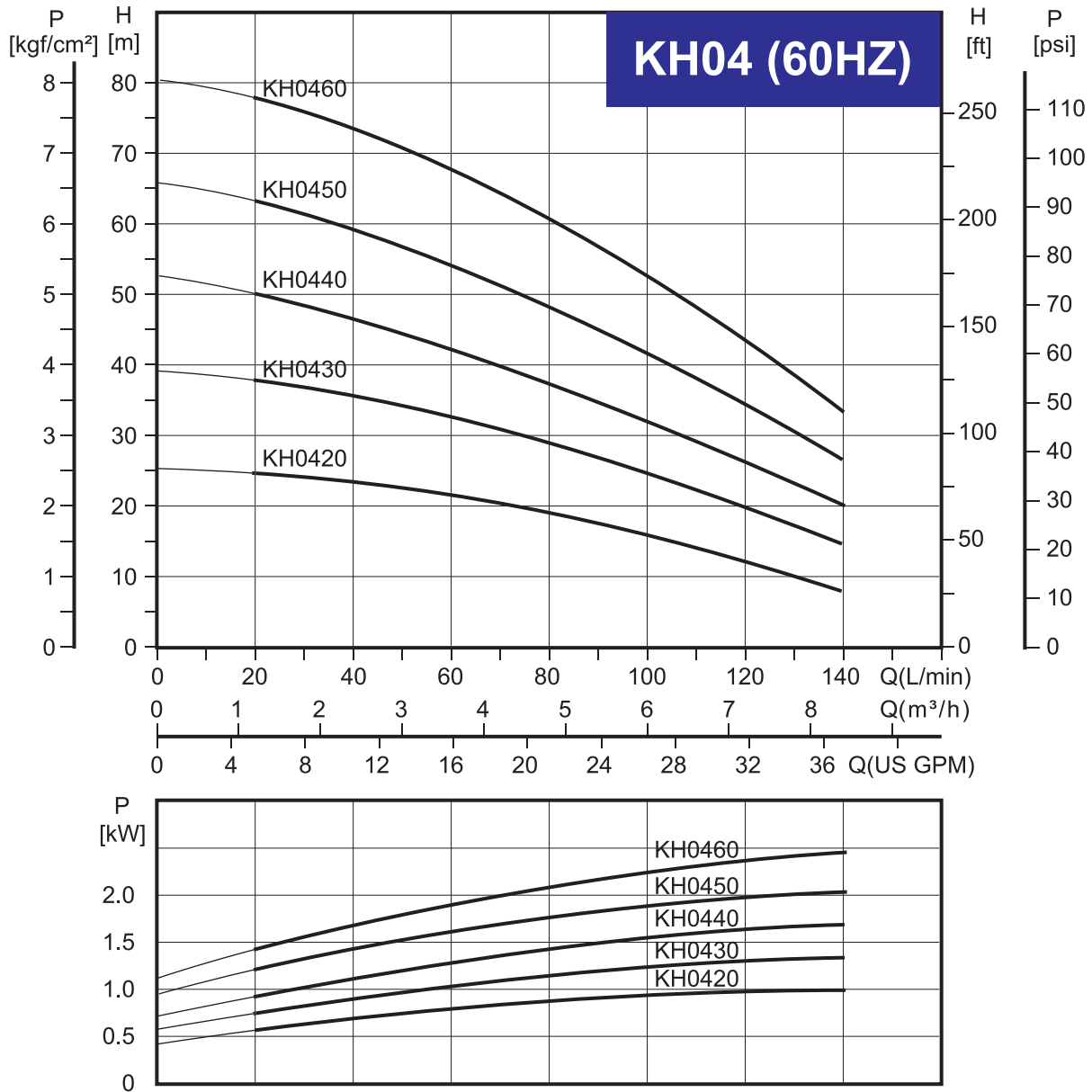

● 規格及電氣資料 (60Hz, 3450 rpm)

型式	額定輸入 (kW)	額定流量 (l/min)	額定揚程 (m)	最高揚程 (m)	相數 (Ø)	電壓 (V)	輸入電流 (A)	訂購編號(*)
KH0420	0.95	100	16	25	1	110~120 / 220~240	9.2 / 5.2	KH0420610
					3	220~240 / 380~415	3.0 / 1.7	KH0420630
KH0430	1.35	100	24	38	1	220~240	6.5	KH0430612
					3	220~240 / 380~415	4.5 / 2.6	KH0430630
KH0440	1.75	100	32	52	1	220~240	8.1	KH0440612
					3	220~240 / 380~415	5.2 / 3.0	KH0440630
KH0450	2.15	100	42	66	1	220~240	10.5	KH0450612
					3	220~240 / 380~415	6.7 / 3.8	KH0450630
KH0460	2.55	100	52	80	1	220~240	11.8	KH0460612
					3	220~240 / 380~415	7.5 / 4.3	KH0460630

(*) 特殊規格附加碼置於訂購編號後面



● 性能曲線

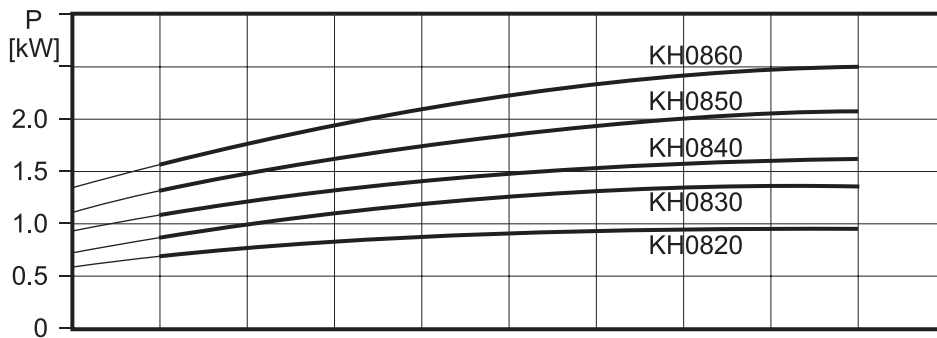
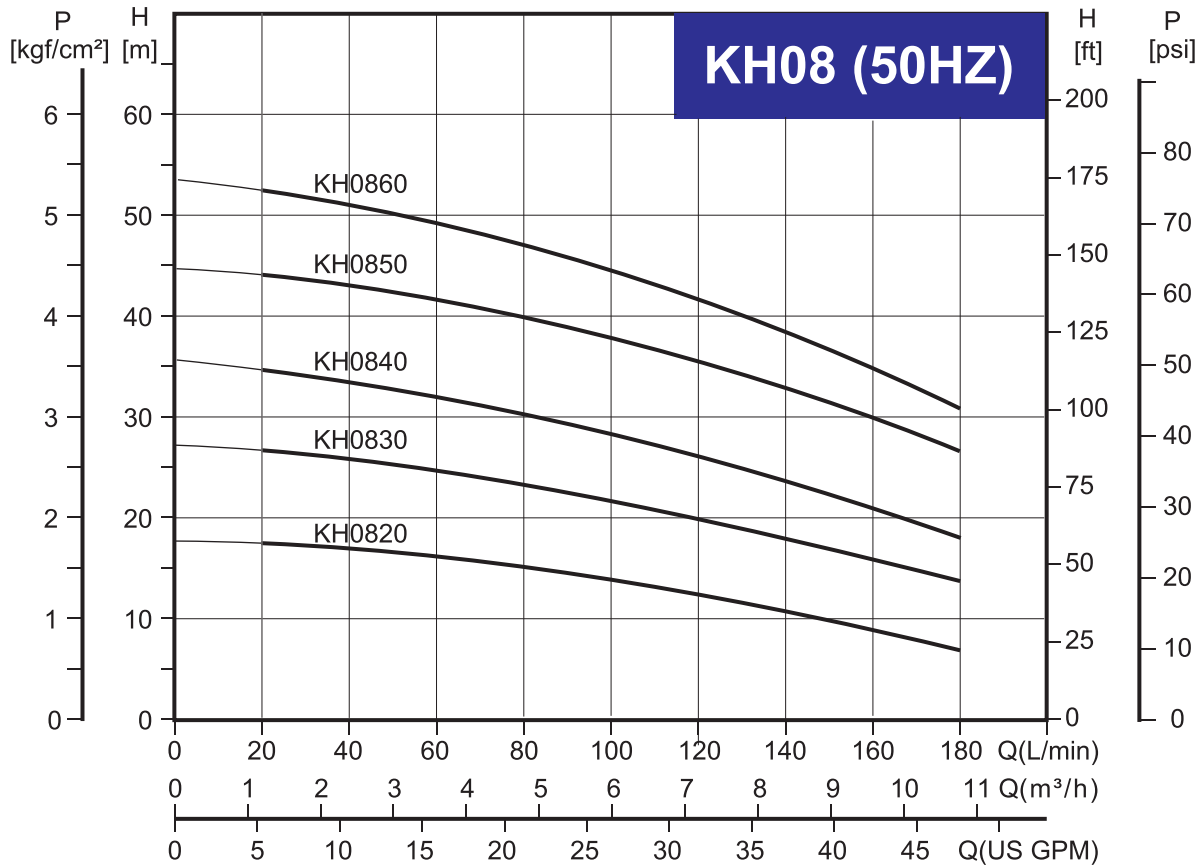

● 規格及電氣資料 (50Hz, 2850 rpm)

型式	額定輸入 (kW)	額定流量 (l/min)	額定揚程 (m)	最高揚程 (m)	相數 (Ø)	電壓 (V)	輸入電流 (A)	訂購編號(*)
KH0820	0.95	120	12	18	1	220~240	3.8	KH0820512
					3	200~255 / 380~440	3.0 / 1.8	KH0820530
KH0830	1.25	120	20	28	1	220~240	5.8	KH0830512
					3	200~255 / 380~440	4.1 / 2.4	KH0830530
KH0840	1.55	120	25	35	1	220~240	7.6	KH0840512
					3	200~255 / 380~440	5.0 / 3.0	KH0840530
KH0850	2.00	120	35	45	3	200~255 / 380~440	6.0 / 3.6	KH0850530
KH0860	2.45	120	40	53	3	200~255 / 380~440	7.0 / 4.1	KH0860530

(*) 特殊規格附加碼置於訂購編號後面



● 性能曲線

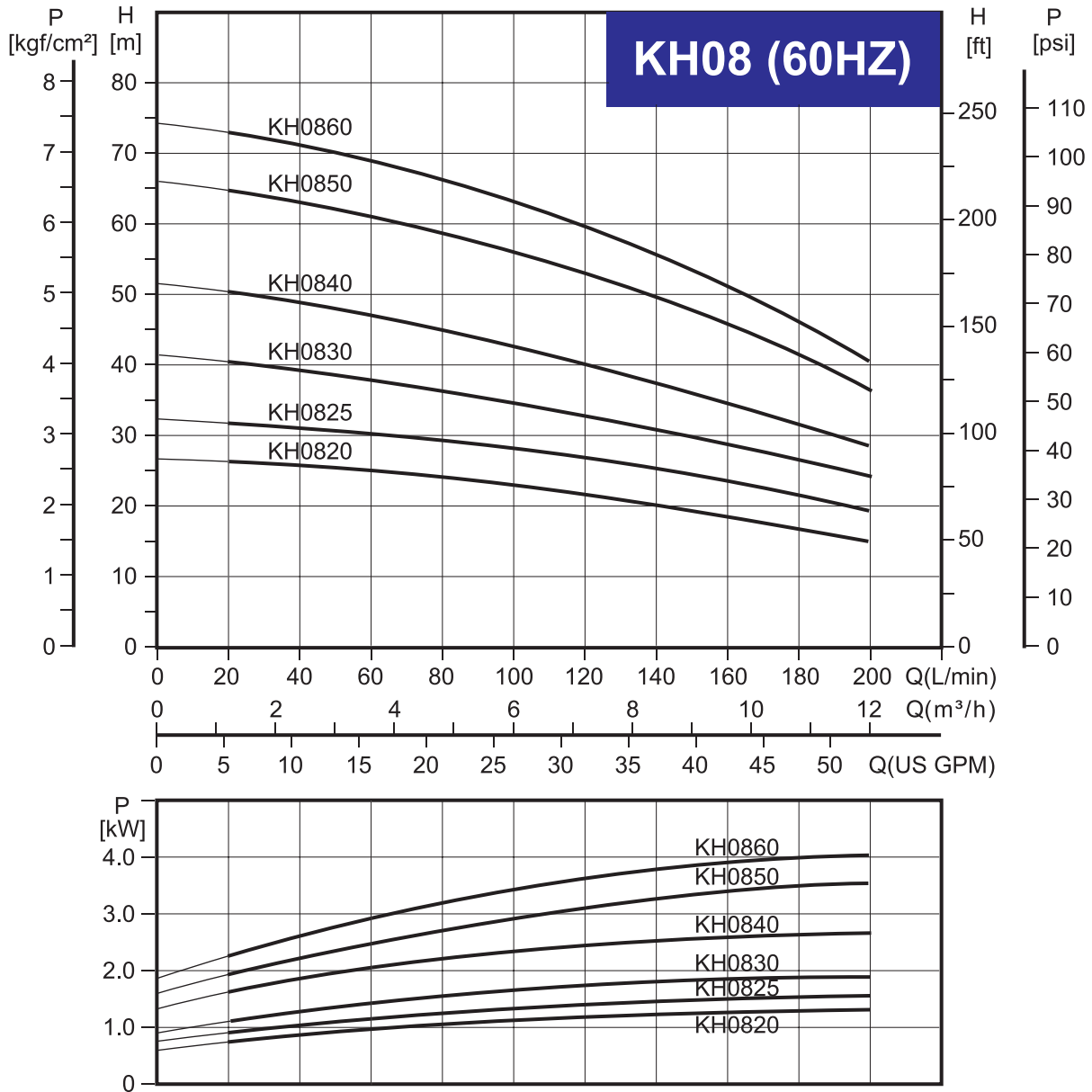

● 規格及電氣資料 (60Hz, 3450 rpm)

型式	額定輸入 (kW)	額定流量 (l/min)	額定揚程 (m)	最高揚程 (m)	相數 (Ø)	電壓 (V)	輸入電流 (A)	訂購編號(*)
KH0820	1.35	140	20	25	1	220~240	6.3	KH0820612
					3	220~240 / 380~415	3.9 / 2.2	KH0820630
KH0825	1.55	140	25	30	1	220~240	8.0	KH0825612
					3	220~240 / 380~415	4.3 / 2.5	KH0825630
KH0830	1.85	140	30	40	1	220~240	9.7	KH0830612
					3	220~240 / 380~415	6.3 / 3.6	KH0830630
KH0840	2.65	140	35	50	1	220~240	7.9 / 4.6	KH0840612
					3	220~240 / 380~415	12.0	KH0840630
KH0850	3.50	140	50	65	3	220~240 / 380~415	11.0 / 6.4	KH0850630
KH0860	4.00	140	55	70	3	220~240 / 380~415	12.5 / 7.2	KH0860630

(*) 特殊規格附加碼置於訂購編號後面



● 性能曲線

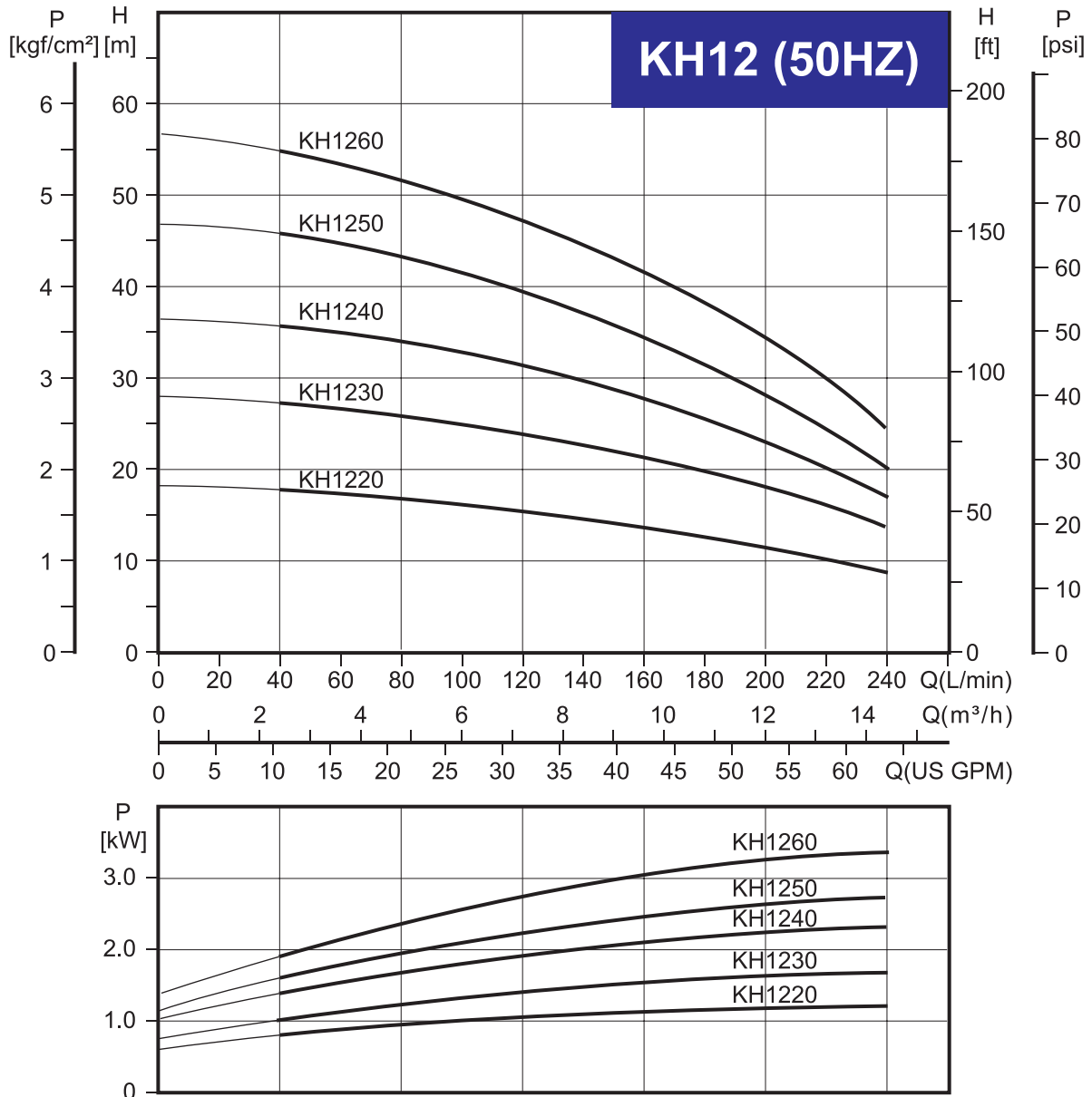

● 規格及電氣資料 (50Hz, 2850 rpm)

型式	額定輸入 (kW)	額定流量 (l/min)	額定揚程 (m)	最高揚程 (m)	相數 (Ø)	電壓 (V)	輸入電流 (A)	訂購編號(*)
KH1220	1.25	180	14	18	1	220~240	3.8	KH1220512
					3	200~255 / 380~440	3.0 / 1.8	KH1220530
KH1230	1.55	180	20	28	1	220~240	5.8	KH1230512
					3	200~255 / 380~440	4.1 / 2.4	KH1230530
KH1240	2.25	180	25	36	3	200~255 / 380~440	5.0 / 3.0	KH1240530
KH1250	2.60	180	32	46	3	200~255 / 380~440	6.0 / 3.6	KH1250530
KH1260	3.25	180	38	55	3	200~255 / 380~440	7.0 / 4.1	KH1260530

(*) 特殊規格附加碼置於訂購編號後面



● 性能曲線

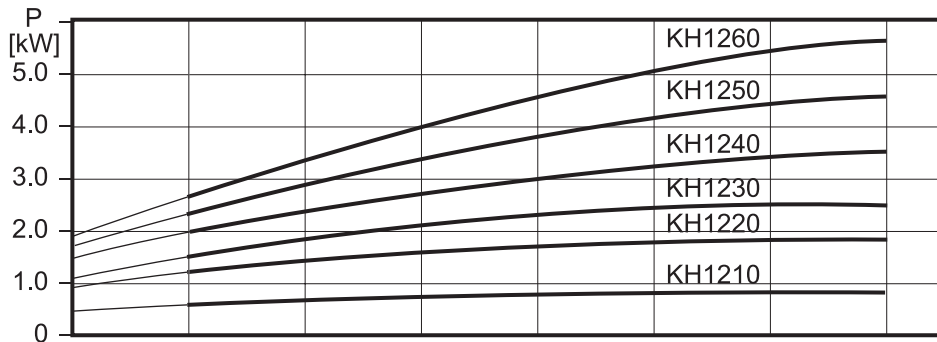
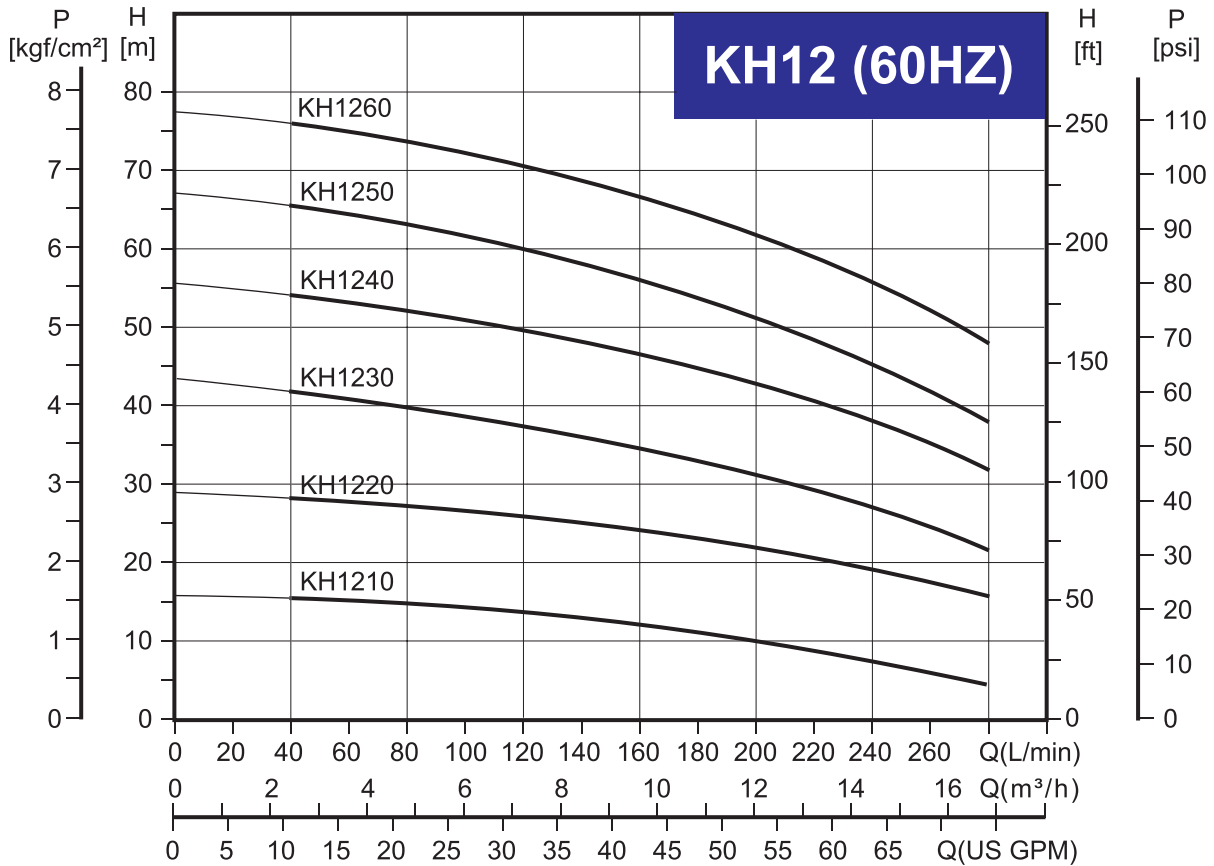

● 規格及電氣資料 (60Hz, 3450 rpm)

型式	額定輸入 (kW)	額定流量 (l/min)	額定揚程 (m)	最高揚程 (m)	相數 (Ø)	電壓 (V)	輸入電流 (A)	訂購編號(*)
KH1210	0.85	200	10	15	1	220~240	4.3	KH1210612
					3	220~240 / 380~415	3.0 / 1.7	KH1210630
KH1220	1.85	200	20	28	1	220~240	9.4	KH1220612
					3	220~240 / 380~415	5.8 / 3.4	KH1220630
KH1230	2.60	200	32	42	1	220~240	12.0	KH1230612
					3	220~240 / 380~415	7.5 / 4.4	KH1230630
KH1240	3.85	200	42	54	3	220~240 / 380~415	11.8 / 6.8	KH1240630
KH1250	4.50	200	50	65	3	220~240 / 380~415	14.8 / 8.5	KH1250630
KH1260	5.50	200	60	75	3	220~240 / 380~415	17.0 / 9.8	KH1260630

(*) 特殊規格附加碼置於訂購編號後面



● 外型尺寸

KH02/04

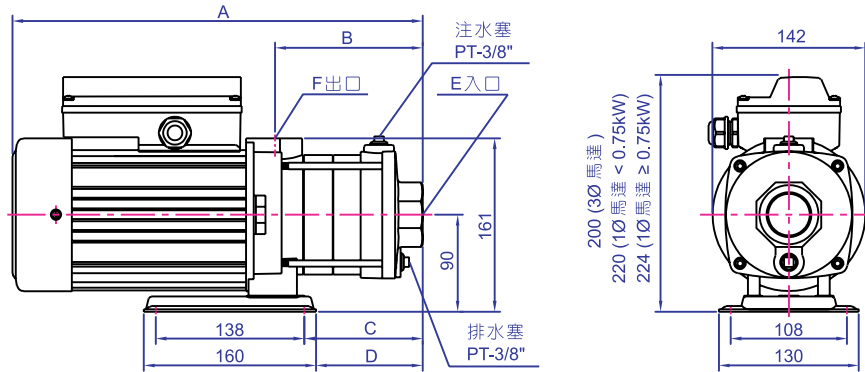

型式	A (mm)	B (mm)	C (mm)	D (mm)	E (inch)	F (inch)	重量 (kg)	
							50Hz	60Hz
KH0210 / KH0220	305	99	74	63	1"	1"	11.8	
KH0230	323	117	92	81	1"	1"	11.9	
KH0240	341	135	110	99	1"	1"	12.0	
KH0250	399	153	128	117	1"	1"	13.5	
KH0260	417	171	146	135	1"	1"	13.6	
KH0420	314	108	83	72	1¼"	1"	11.8	
KH0430	381	135	110	99	1¼"	1"	13.4	
KH0440	408	162	137	126	1¼"	1"	14.2	
KH0450	435	189	164	153	1¼"	1"	14.5	
KH0460	462	216	191	180	1¼"	1"	16.5	

KH08/12

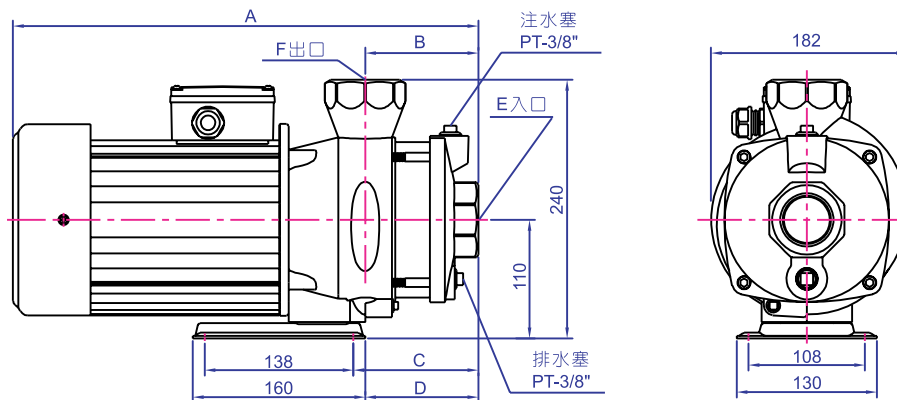

型式	A (mm)	B (mm)	C (mm)	D (mm)	E (inch)	F (inch)	重量 (kg)	
							50Hz	60Hz
KH0820	330	73	84	73	1½"	1½"	18.5	18.5
KH0825	402	105	116	105	1½"	1½"	--	19.5
KH0830	402	105	116	105	1½"	1½"	19.5	20.5
KH0840	432	105	116	105	1½"	1½"	20.5	26.0
KH0850	464	137	148	137	1½"	1½"	26.0	28.0
KH0860	464	137	148	137	1½"	1½"	26.0	28.0
KH1210	330	73	84	73	1½"	1½"	--	17.5
KH1220	370	73	84	73	1½"	1½"	20.5	19.5
KH1230	432	105	116	105	1½"	1½"	20.5	25.5
KH1240	432	105	116	105	1½"	1½"	25.5	28.0
KH1250	464	137	148	137	1½"	1½"	29.5	33.5
KH1260	464	137	148	137	1½"	1½"	29.5	33.5



● 構造/材質

項目	零件名稱	材 質	項目	零件名稱	材 質
1	馬 達	鋁框 / F 級絕緣	8	軸 套	SUS304
2	主 軸	SC45C+SUS304	9	防鬆螺帽	SUS304
3	泵 浦 殼	FC200	10	導水器組	SUS304
4	機械軸封	VITON/SiC	11	泵浦入口	FC200
5	葉 輪 組	SUS304	12	注 水 塞	FC200
6	軸 套	SUS304	13	排 水 塞	FC200
7	軸 套	SUS304	14	底 座	S45C

KH02/04

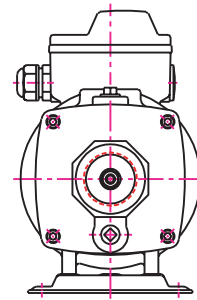
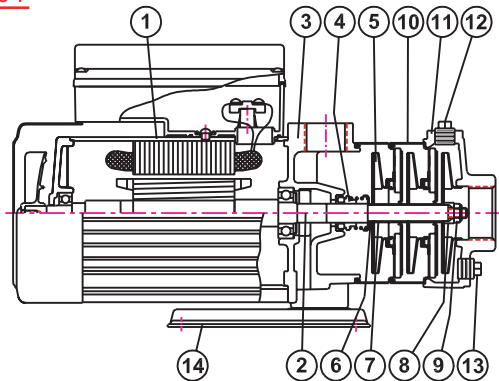

KH08/12

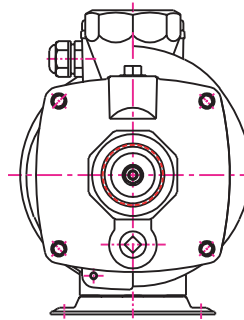
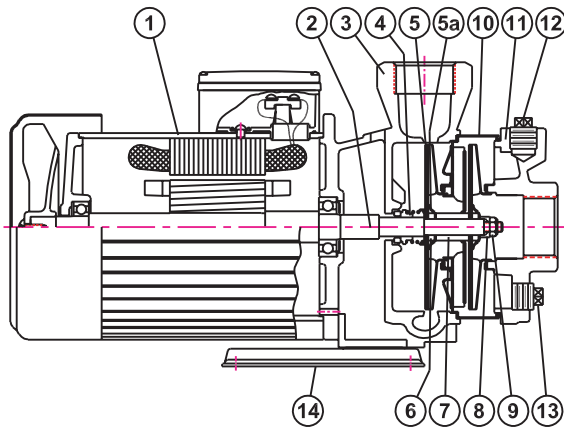

經 銷

ISO9001 認證合格



木川工業股份有限公司

KIKAWA PUMP CO., LTD